



Strasbourg,  
école d'architecture



同濟大學  
TONGJI UNIVERSITY

# The place of Death in Chinese megacities

*Spatial reflections of Shanghai cemeteries under  
urban transformations*

Master thesis supervisor :  
GAN Jing - 干靚 | Andreea Grigorovoschi

Marie FRUIQUIERE

# Summary

- **the choice of the subject**
- **the research question**
- **approach and methodology**
- **results**
- **conclusion**
- **opening and critical feedback**
- **contributions and future**

the choice of the subject

魄

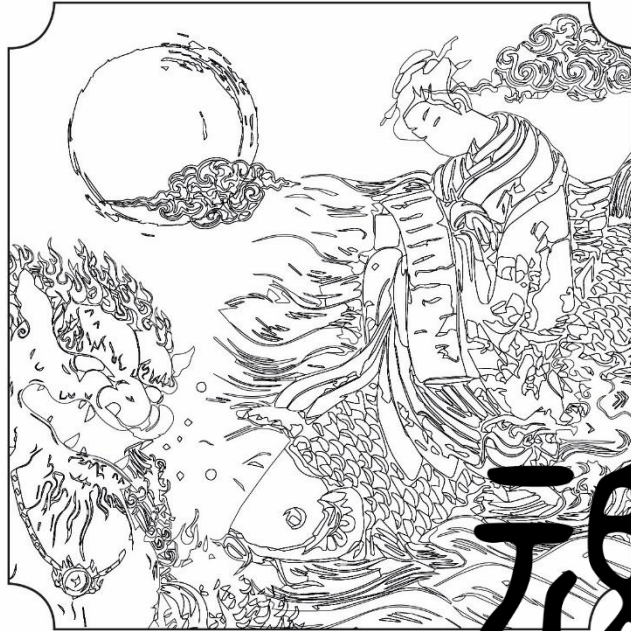
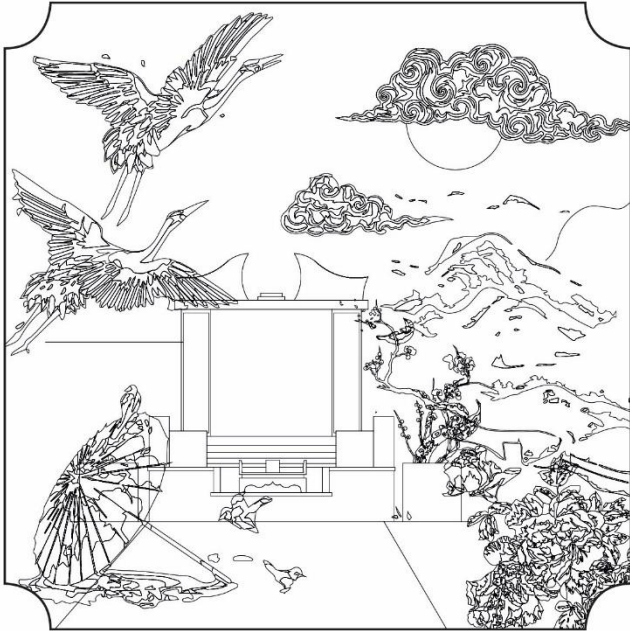
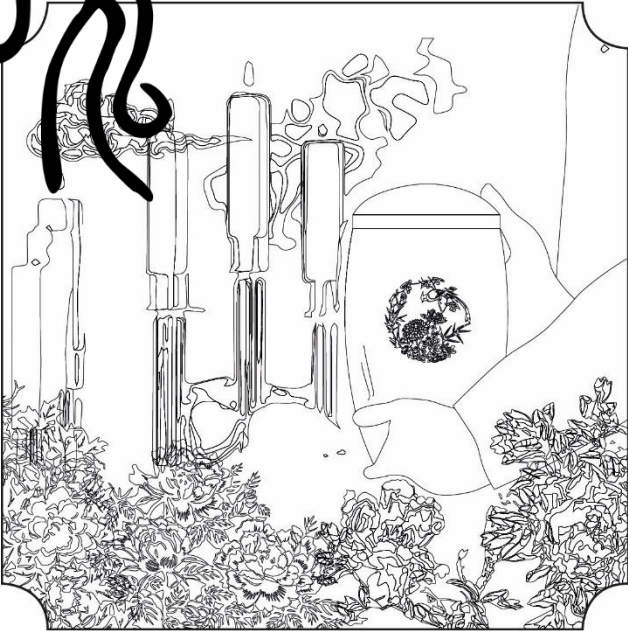

魂

# the research question

**What is the current place of cemeteries under the influence of socio-politico-economic changes in urbanized Chinese megacities such as Shanghai ?**

or

**How do funerary spaces, but also mourning practices, adapt in an increasingly urban and mobile society?**

# approach and methodology

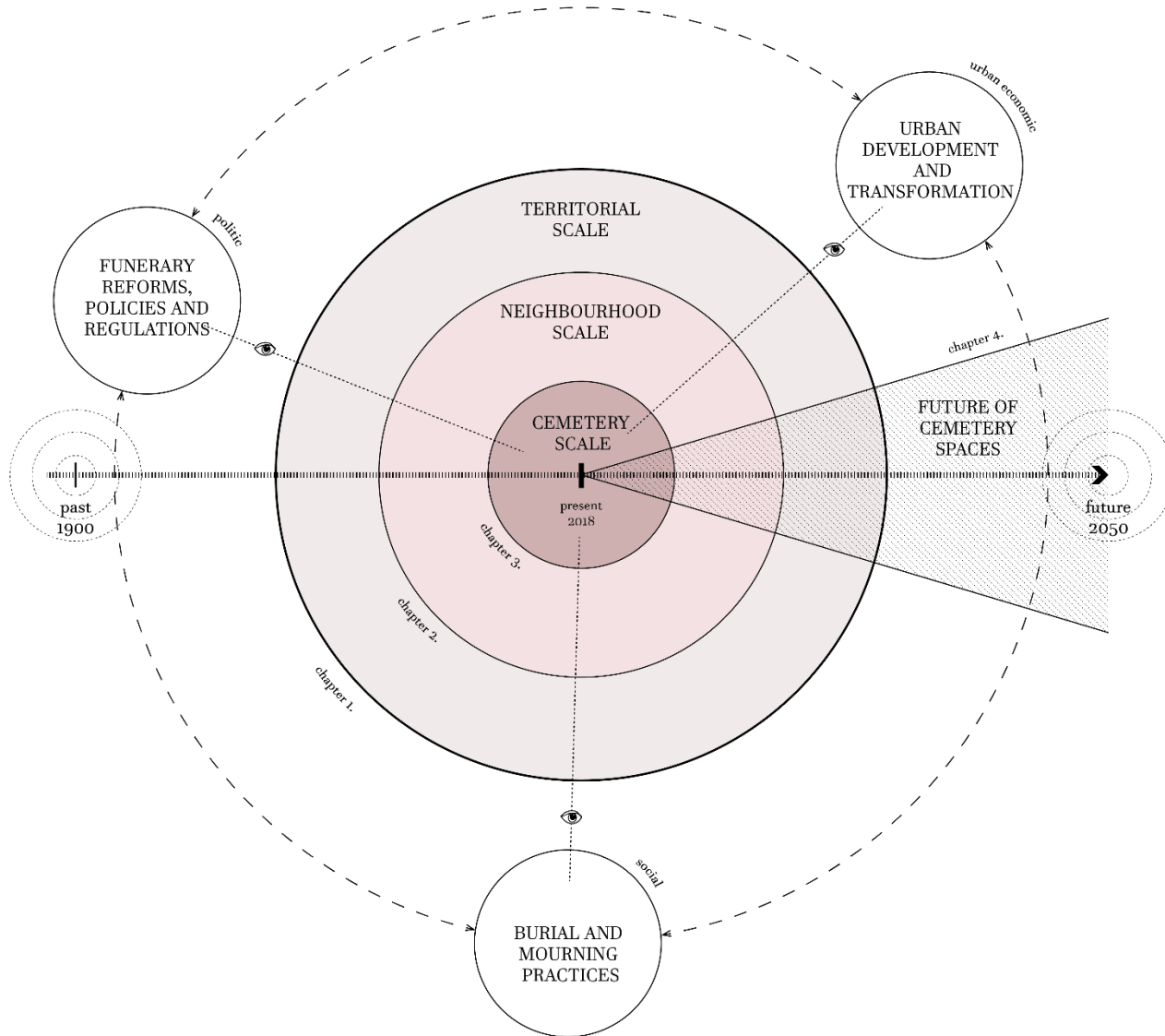

- Understand the spatiality of cemeteries
- Understand the effect of regulations on these spaces
- Understand the evolution of the bereavement relationship in Chinese society until today

Questions observed through Shanghai cemeteries,

under  
**socio-politico-economic influences**

but also under  
**temporal evolution**



# approach and methodology

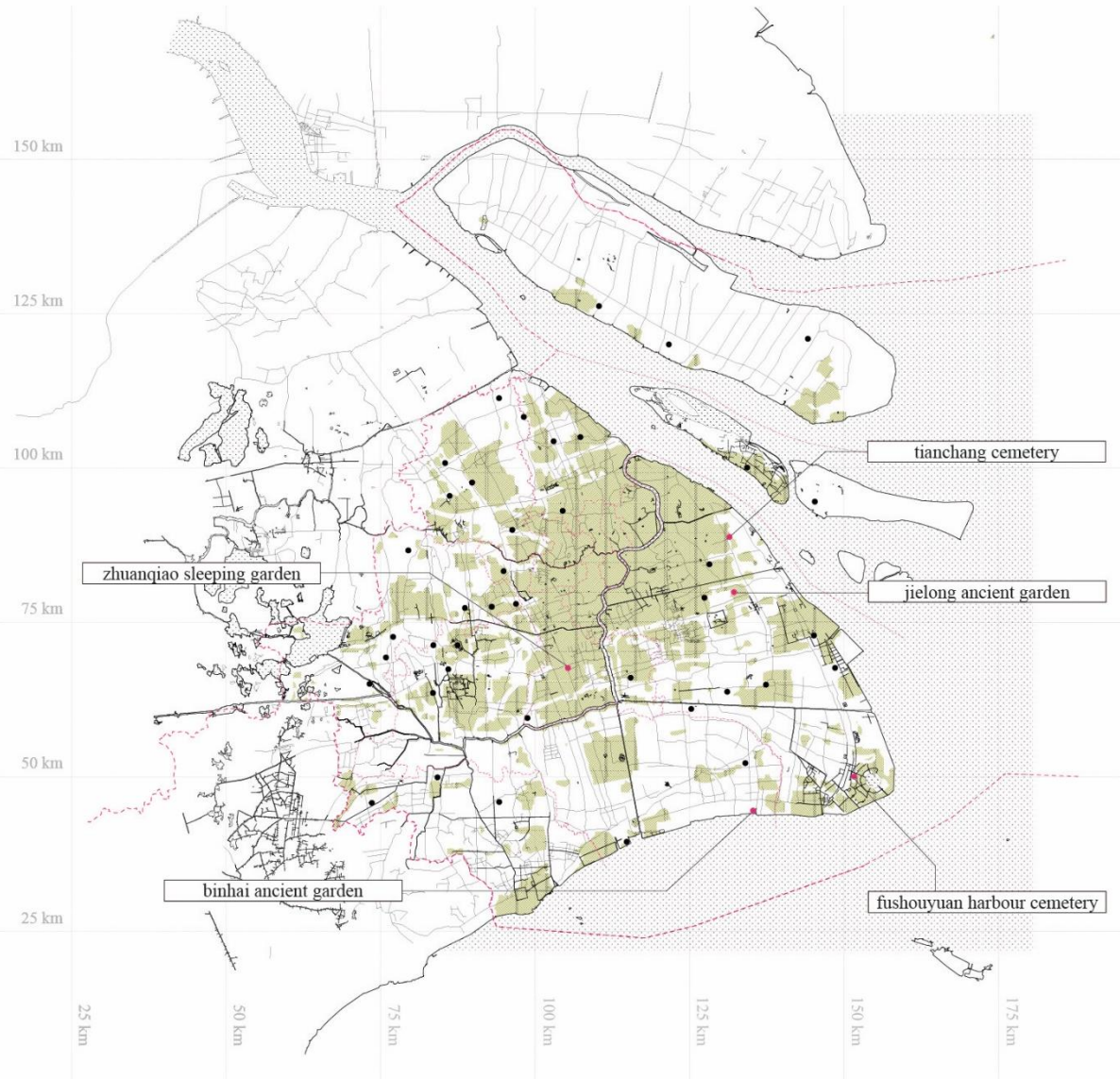

## ● 5 Shanghai cemeteries as case studies :

- Tianchang Cemetery - 上海天长公墓
- Zhuanqiao Sleeping Garden - 上海市颛桥寝园
- Binhai Ancient Garden - 上海滨海古园
- Jielong Ancient Garden - 界龙古园
- Fushouyuan Harbour Cemetery - 界龙古园
  - Selected according to **their creation date, their size and their distance** from the center of Shanghai to constitute a representative panel

## ● Analysis of laws and regulations about funerary places and practices

- Official governmental documents published by the municipality
- Interview with **Wu FangFang**, Urban planner of the *Shanghai Urban Planning and Design Institute*, in charge of the **Shanghai funerary spaces planning for Shanghai 2035**, in May 2018.

## ● Online survey, *A cemetery for today and tomorrow ?* (现状与未来的墓葬空间)

- Conducted online, 45 collected answers, from October 2018 to May 2019

## ● Supplemented by literature :

- Literature references in **sociology, anthropology** or **philosophy** fields, but lack in our disciplinary field and all the more so in burials in China today
- Both **European** and **Chinese references** as much as possible, to mirror with **international cases** thanks to scientific articles analysis

# results

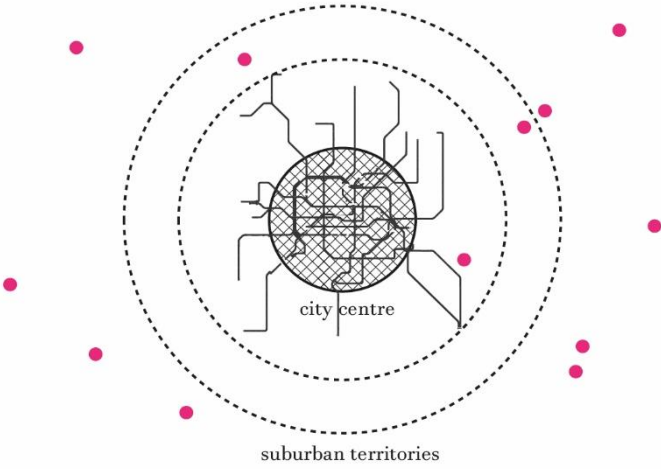

*Territory scale*  
**rejected**

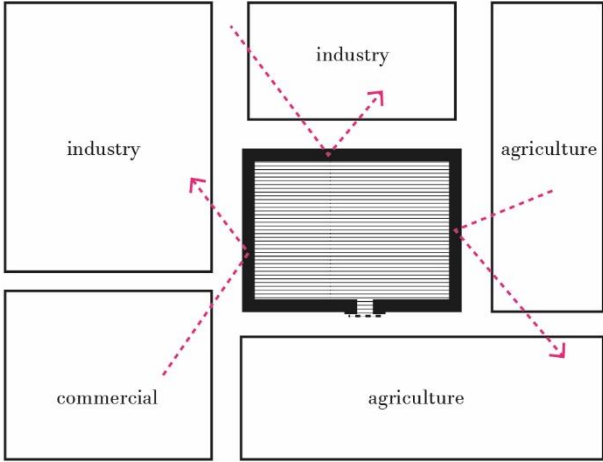

*Neighborhood scale*  
**isolated**

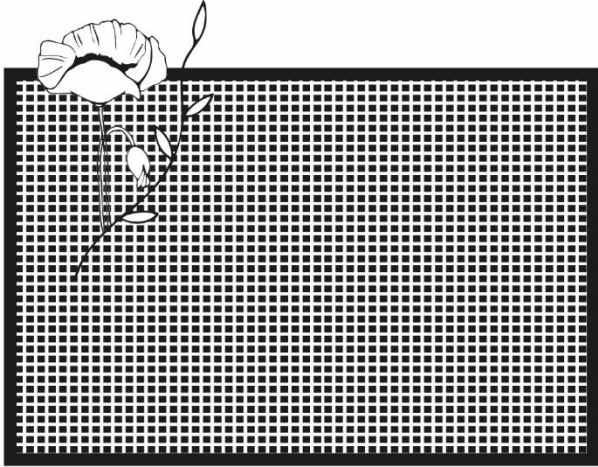

*Cemetery scale*  
**rationalized**



# results

*Burial grounds within the metropolitan territory of Shanghai : The gradual remoteness of cemeteries*

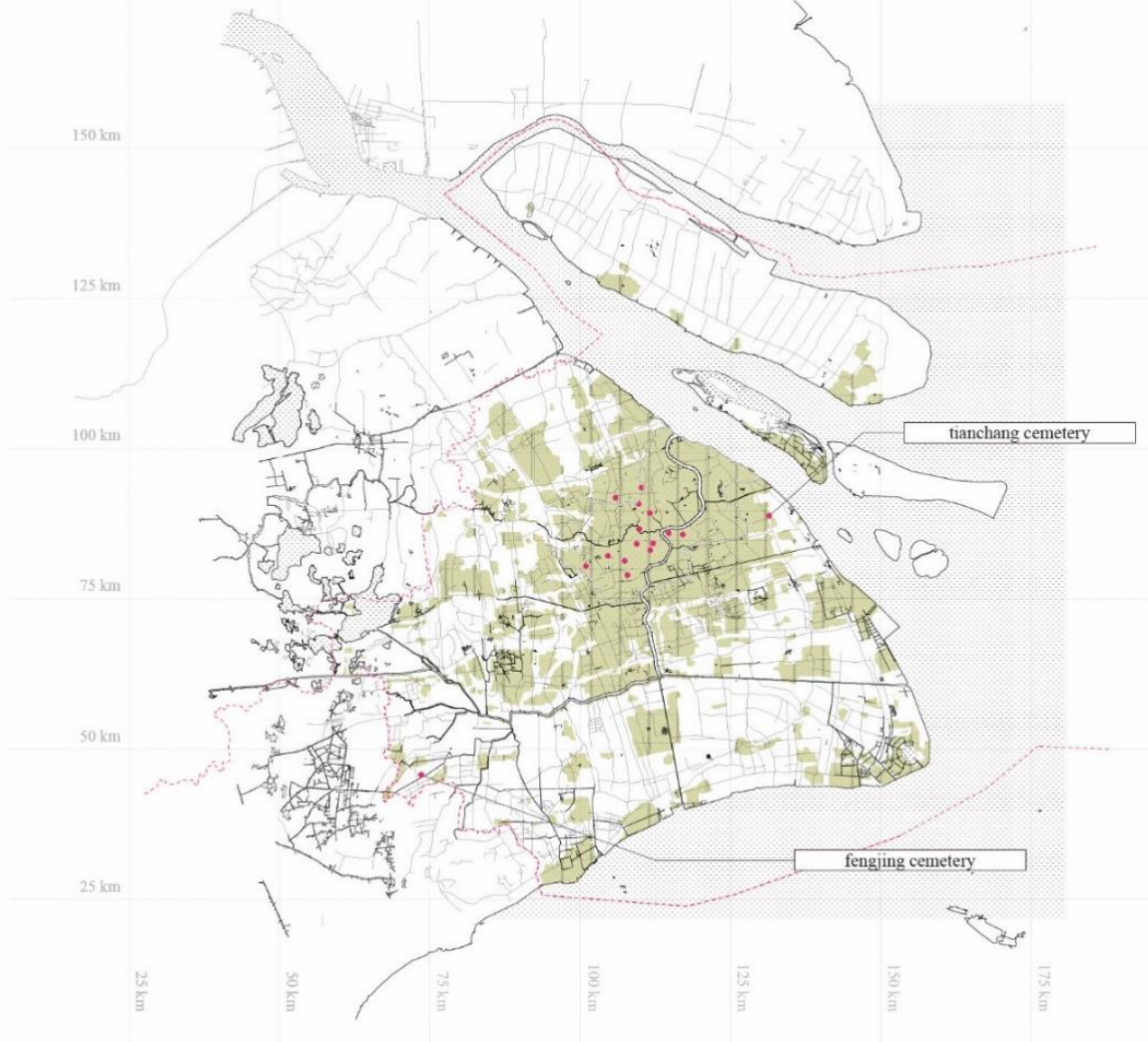

Former cemeteries in 1940 destroyed by massive urbanization  
*Personal production*

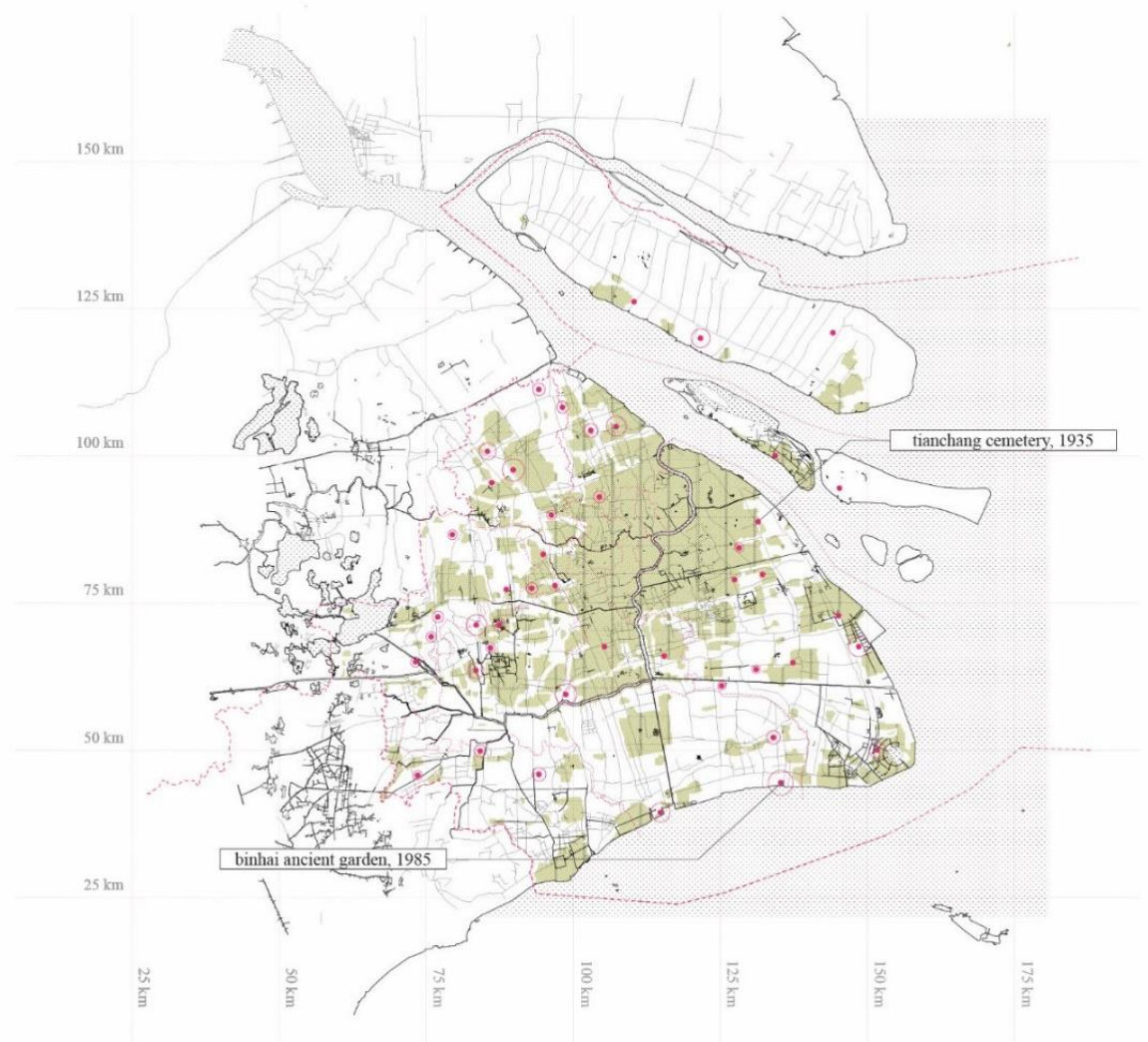

The influence of urbanization on cemeteries surfaces  
*Personal production*



# results

*Burial grounds within the metropolitan territory of Shanghai : The gradual remoteness of cemeteries*

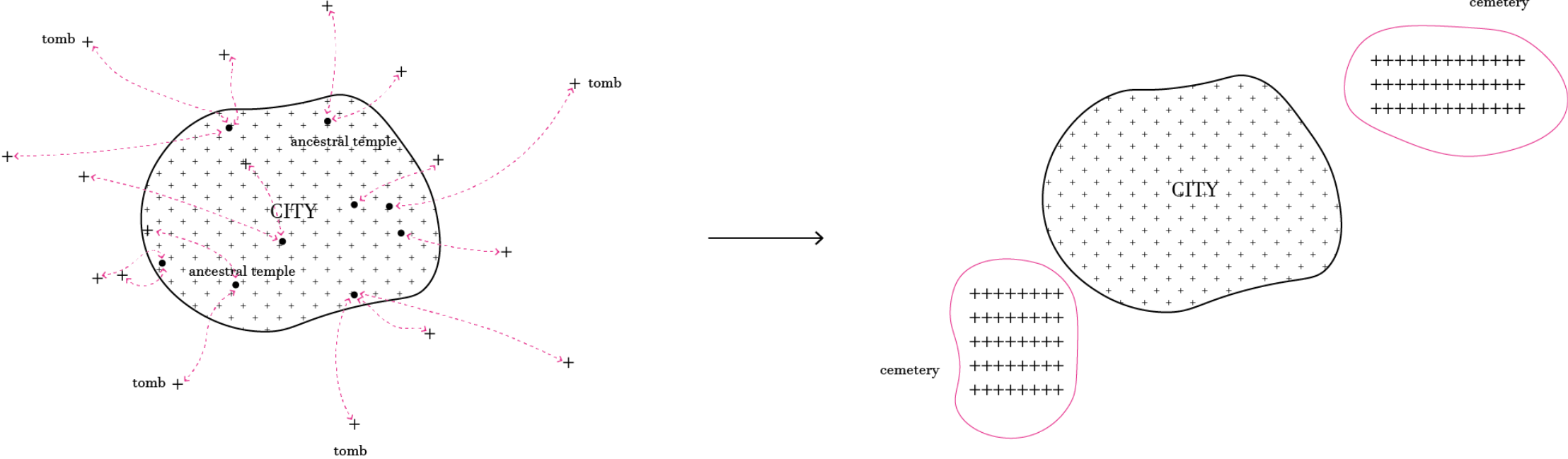

From domestic spaces to public cemetery to bury and worship deceased

*Personal production*

# results

*Burial grounds within the metropolitan territory of Shanghai : The gradual remoteness of cemeteries*

Name	Tianchang Cemetery 天长公墓	Zhuanqiao Sleeping Garden 颛桥寝园	Jielong Ancient Garden 界龙古园	Shanghai Binhai Ancient Garden 滨海古园	Shanghai Fushouyuan Harbour Cemetery 上海福寿园海港陵园
Distance to the city centre as the crow flies	19 km	19 km	20 km	48 km	52 km
Travel time by car	0h40 (21.8 km)	0h39 (23.7 km)	0h43 (31.1 km)	1h17 (63.8 km)	1h13 (70.8 km)
Travel Time by metro	0h44 (20.9 km)	1h01 (22.4 km)	1h20 (26.3 km)	No itinerary available	No itinerary available
Travel time by bus	2h04 (24.4 km)	1h50 (22.2 km)	1h28 (32.0 km)	3h21 (64.2 km)	3h25 (79.7 km)
Travel time by metro + bus	1h12 (23.5 km)	1h13 (22.7 km)	1h09 (26.3 km)	2h39 (64.2 km)	2h09 (66.2 km)
Travel time by bicycle	1h58 (23.3 km)	1h59 (23.4 km)	2h15 (26.6 km)	4h48 (57 km)	5h24 (64.1 km)

Former cemeteries in 1940 destroyed by massive urbanization  
*Personal production*

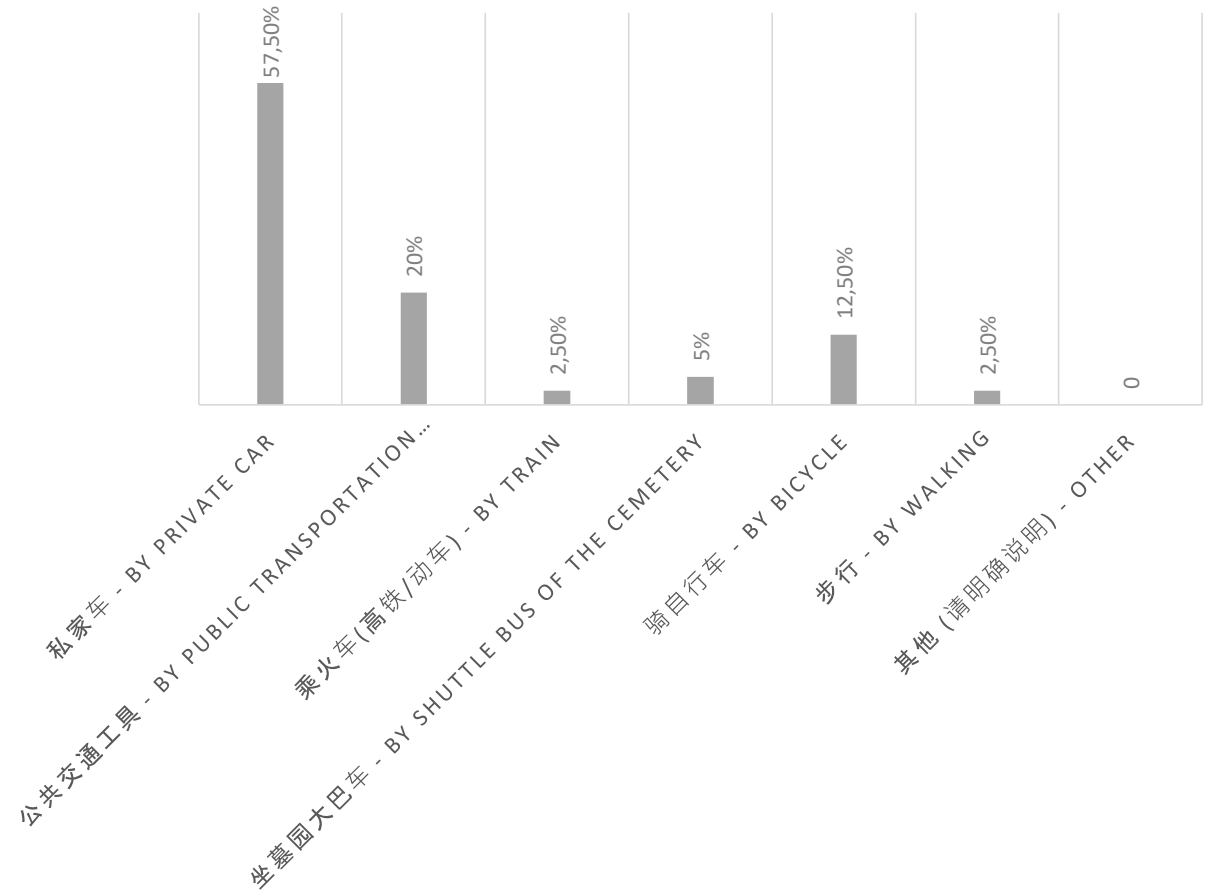

Commuting toward cemeteries mainly done by car  
*Personal production based on the results of the questionnaire “现状与未来的墓葬空间 - A cemetery for today and tomorrow ?” distributed to Shanghainese residents*

# results

*Burial grounds within the metropolitan territory of Shanghai : The gradual remoteness of cemeteries*



2005



2019

Cemeteries facing urbanization - Jielong Ancient Garden  
*Personal production*

# results

*The relationship between cemeteries and their close environment : Spatialization of a paradoxal relationship to the death*

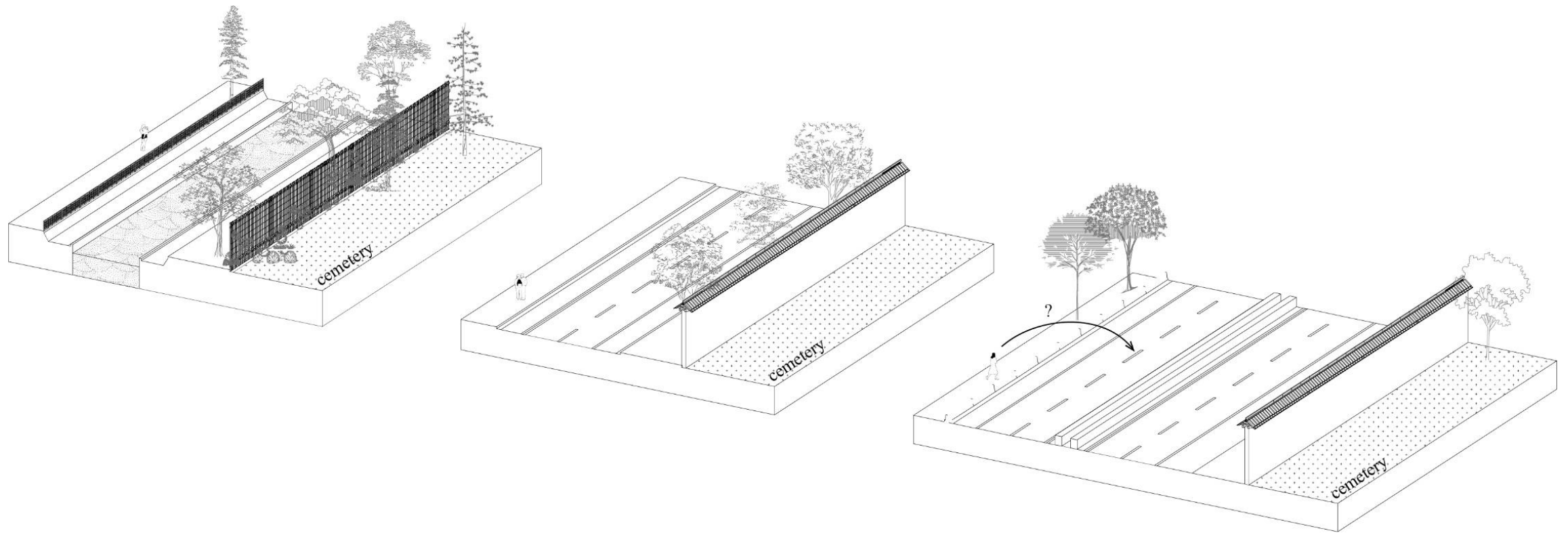

Barriers multiplication to protect and protect oneself from the deceased  
*Personal production*



# results

*The relationship between cemeteries and their close environment : Spatialization of a paradoxal relationship to the death*

Tianchang cemetery



Jielong Ancient Garden



Binhai Ancient Garden



Barriers multiplication to protect and protect oneself from the deceased  
*Personal photographs*

# results

*The very space of the cemetery : Grave optimization to face land and economic pressure*

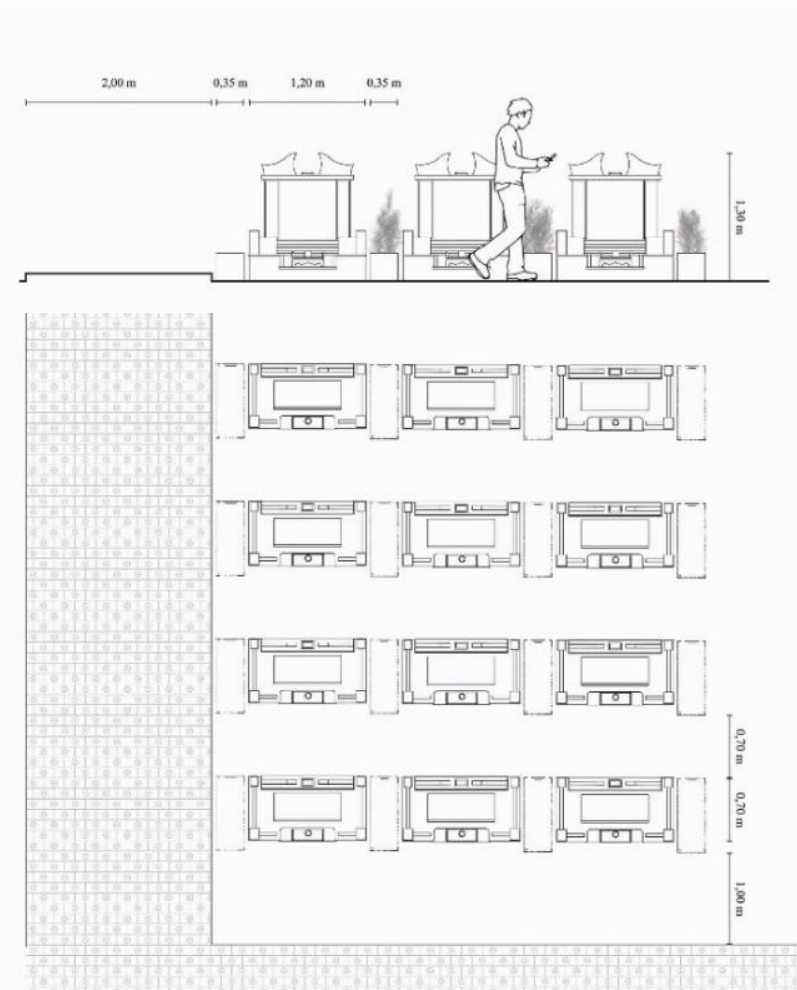

Rationalization in the Shanghainese grave pattern  
*Personal production*

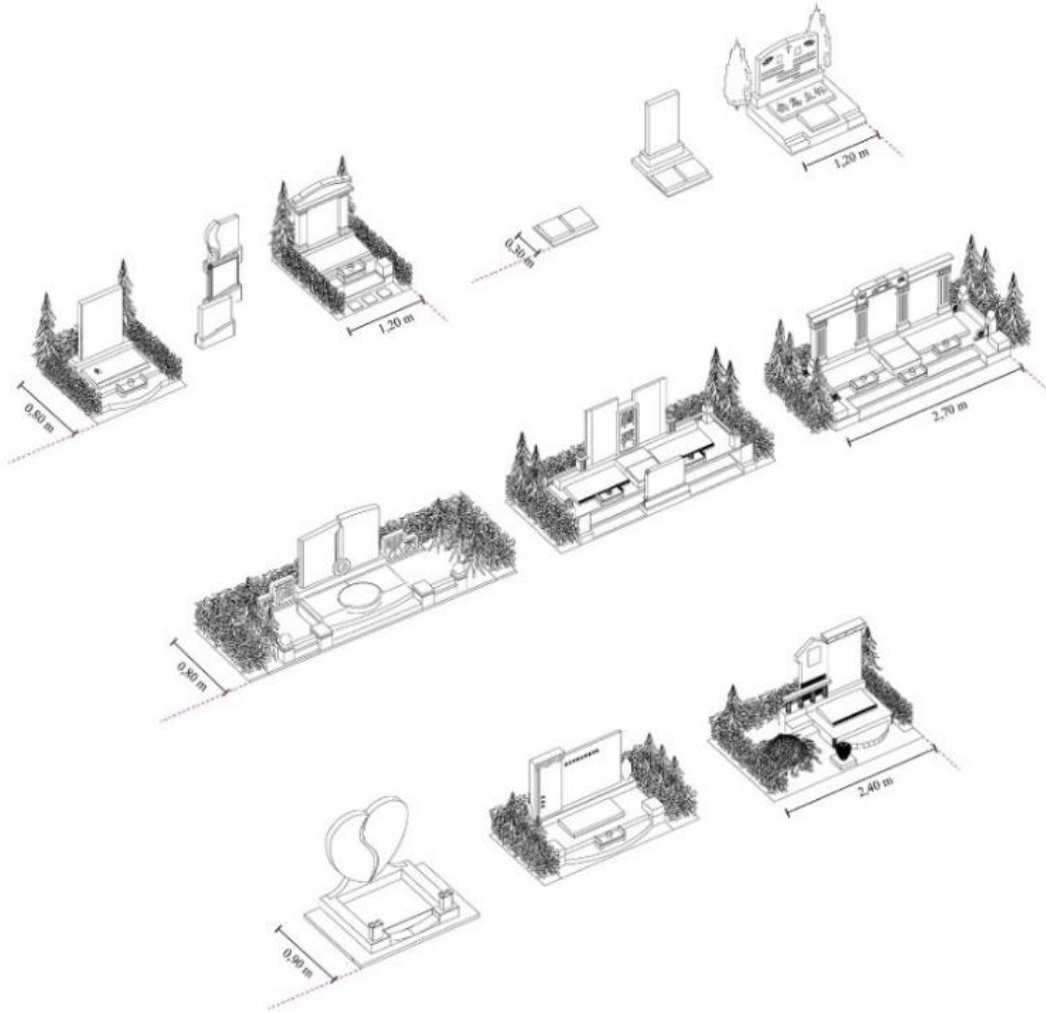

Various types of graves from lawn burial to artistic grave  
*Personal production*

# results

*The very space of the cemetery : Grave optimization to face land and economic pressure*

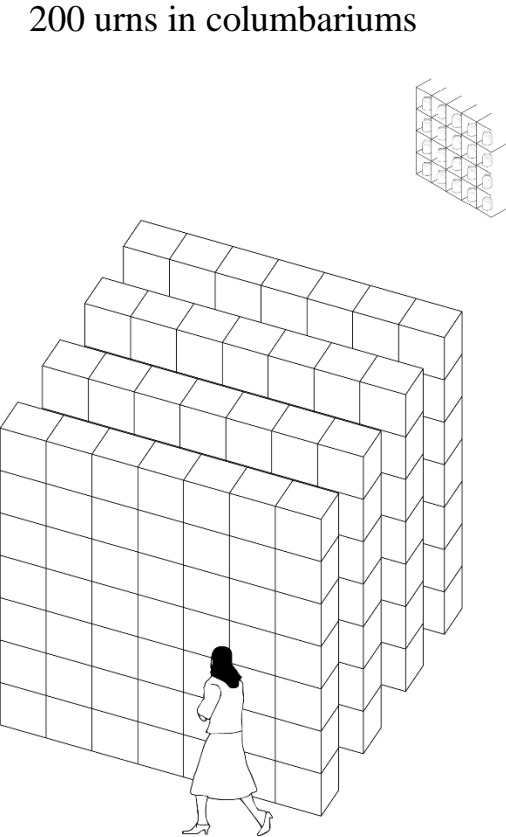
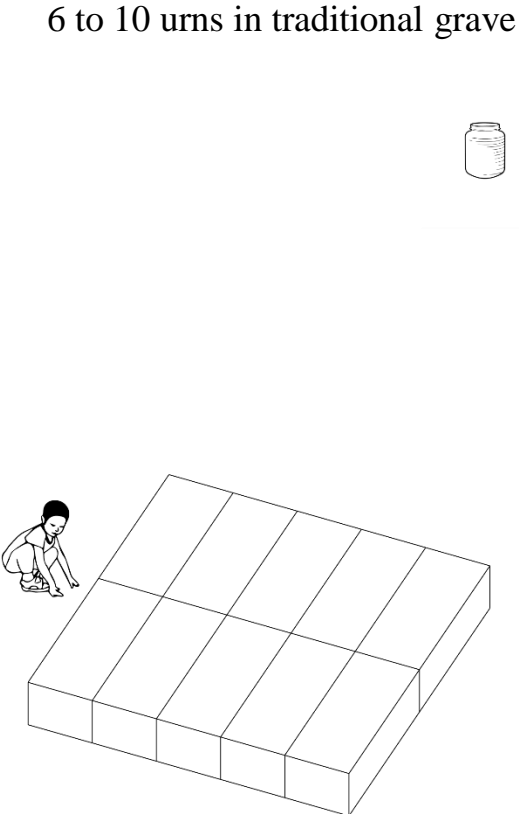
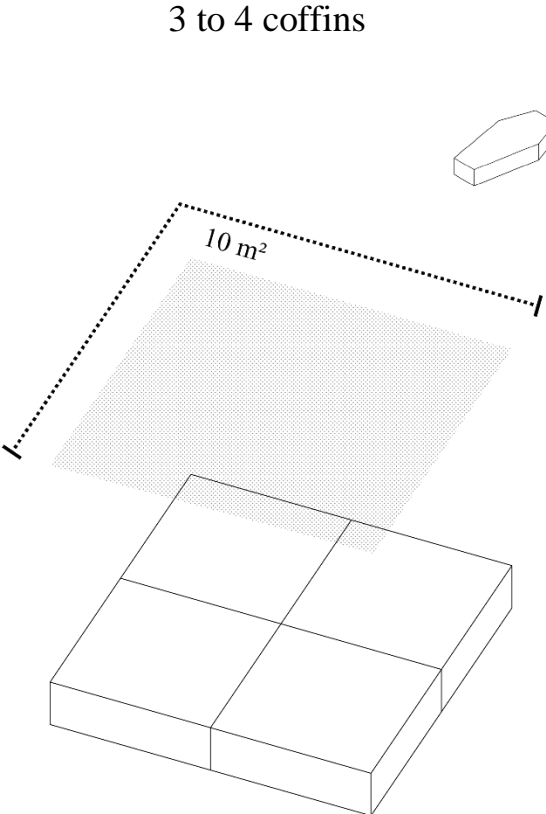

Vertical optimization of graves  
*Personal production*



# results

*The very space of the cemetery : Grave optimization to face land and economic pressure*

Fushouyuan Harbour Cemetery



Zhuanqiao Sleeping Garden



Fushouyuan Harbour Cemetery



The evolution of the Shanghaiese funerary landscape between nature, spatial constraints and a growing desire of personalization  
*Personal photographs*



# results

## *Funerary spaces of tomorrow : The dematerialization of the cemetery through ecological burial*

Progressive acceptance of sea burial since 2003

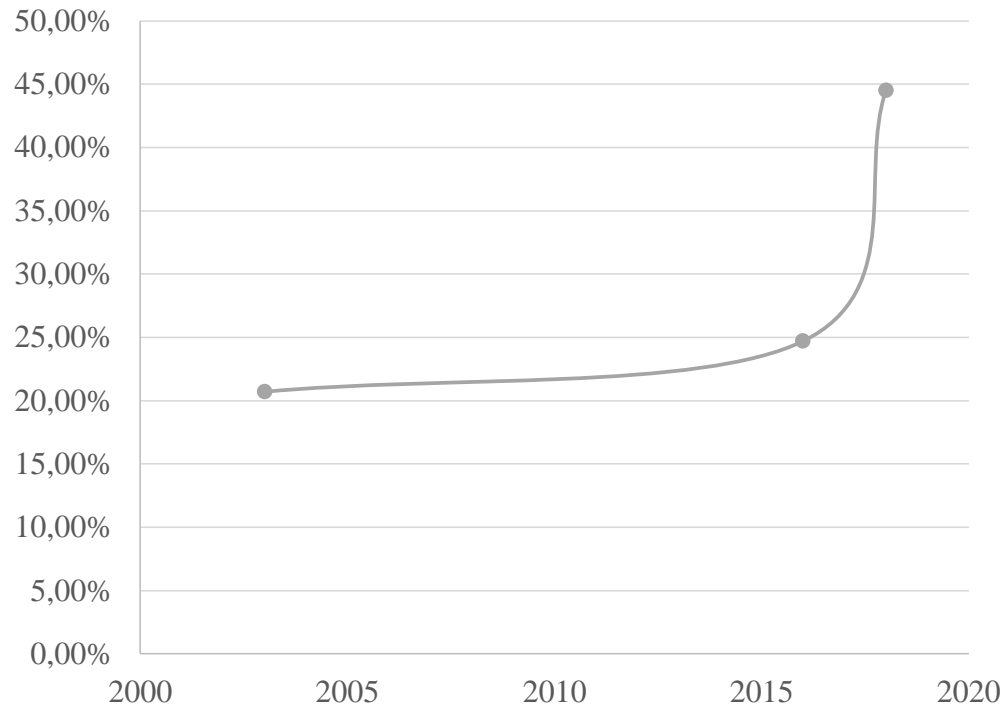

Progressive acceptance of sea burial since 2003

*Personal production based on the results of the questionnaire “现状与未来的墓葬空间 - A cemetery for today and tomorrow ?” distributed to Shanghainese residents*

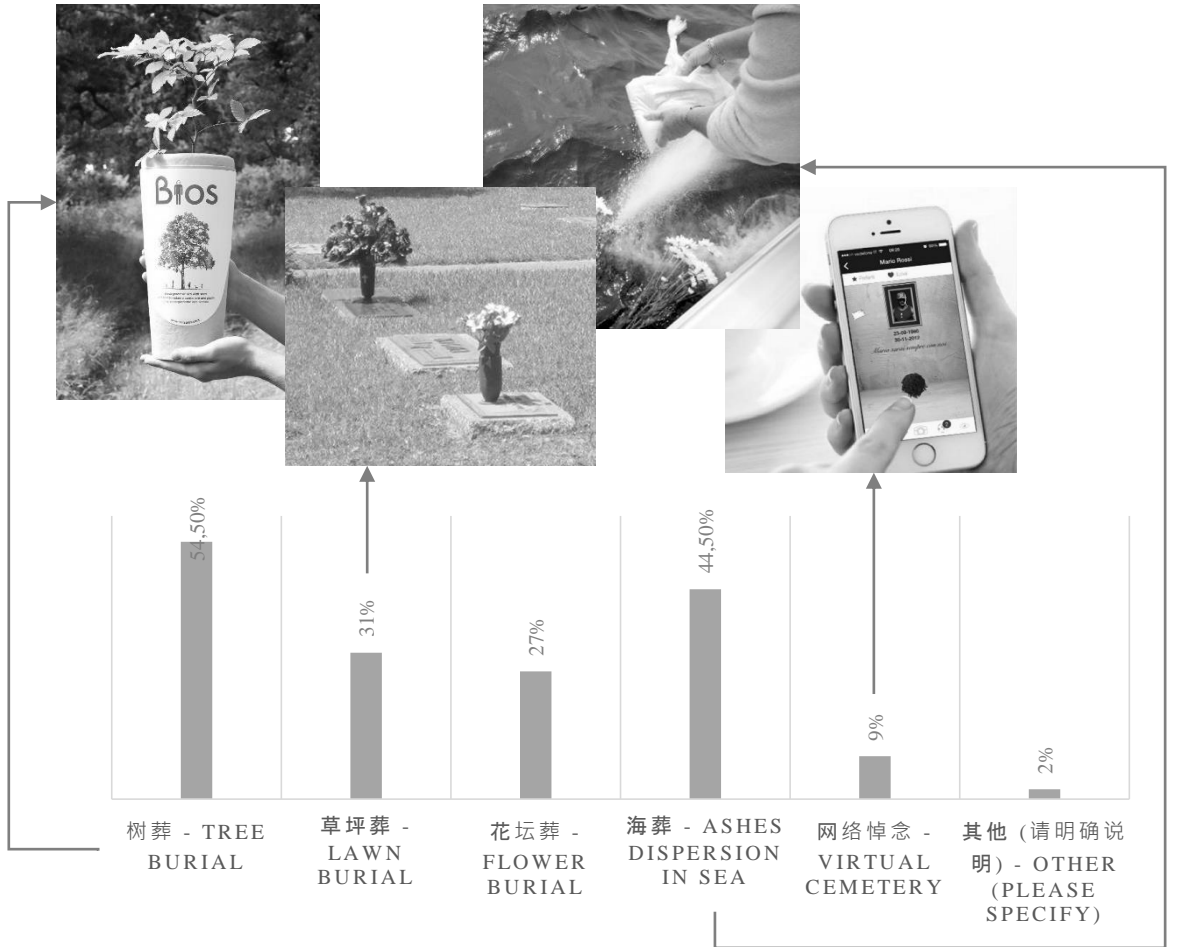

Global acceptance of new ecological burial practices except for virtual cemetery

*Personal production based on the results of the questionnaire “现状与未来的墓葬空间 - A cemetery for today and tomorrow ?” distributed to Shanghainese residents*

# results

*Funerary spaces of tomorrow : The dematerialization of the cemetery through ecological burial*

Jielong Ancient Garden

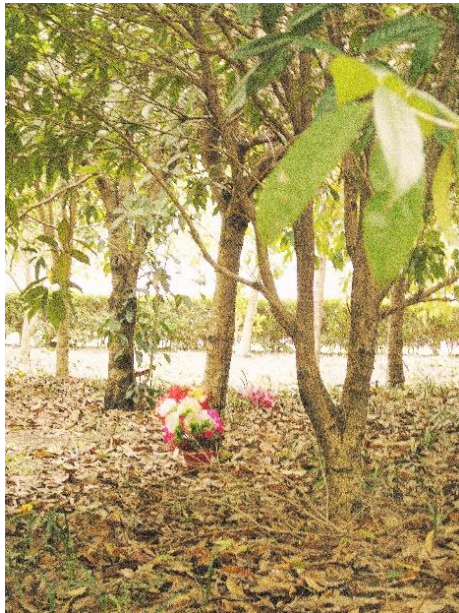

Jielong Ancient Garden



Fushouyuan Harbour Cemetery



Transformation of the Shanghainese deathscape in favor of ecological burials  
*Personal photographs*

# conclusion

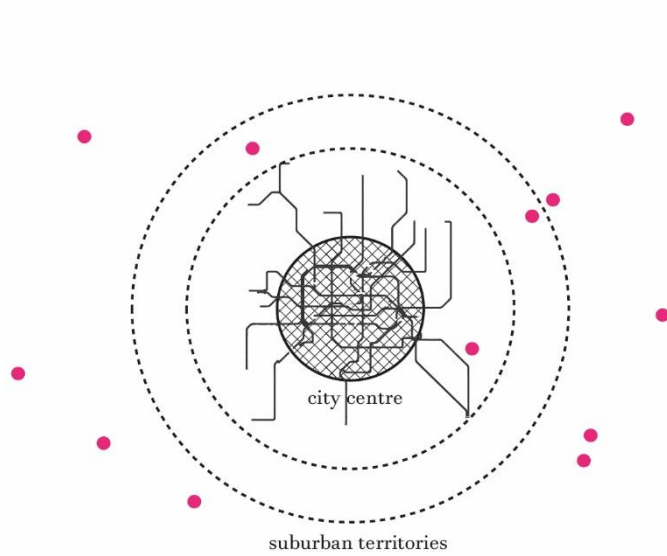

*Territory scale*  
**rejected**

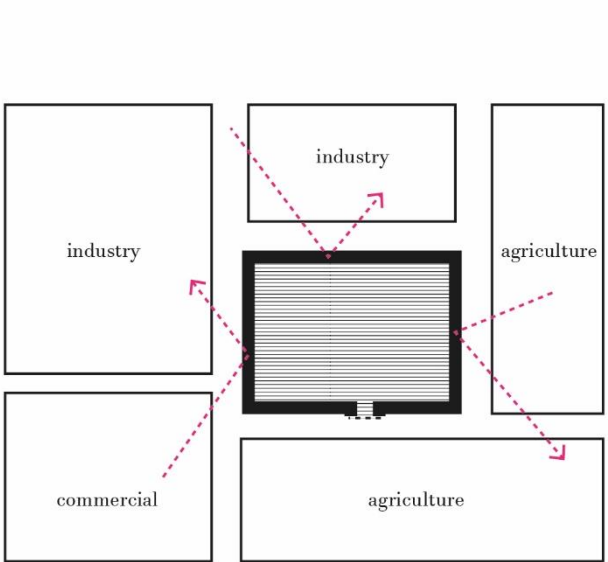

*Neighborhood scale*  
**isolated**

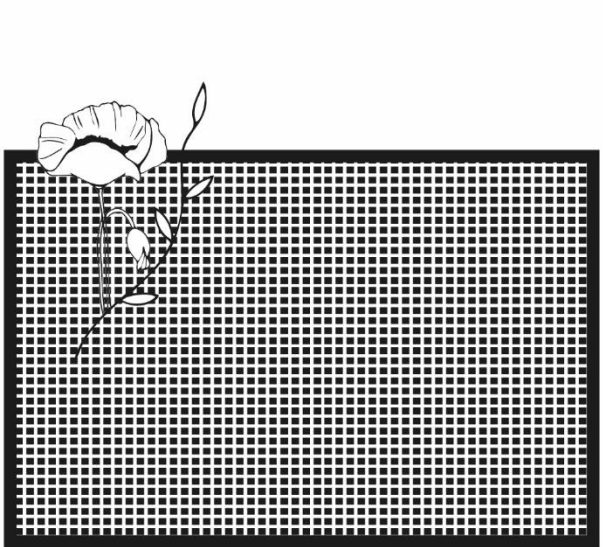

*Cemetery scale*  
**rationalized**

# conclusion



**Cemeteries are tormented places in constant adaptation despite the permanence of burial. They reflect the evolution of society and our relationship to death, whose spatiality raises today more and more questions in an increasingly urban, mobile and virtual society.**



# opening and critical feedback

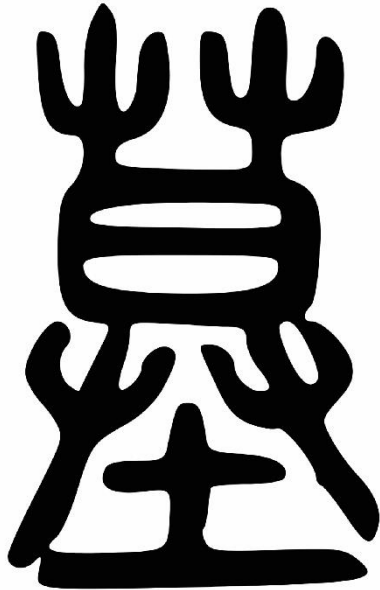

- A non-exhaustive research but which tries to combine **a quantitative** as well as **a qualitative approach**
- **Emphasize a precise case study** or **expand the research to new cemeteries**
- **Make a comparison :**
  - Mirror **urban and rural** situation
  - **Compare to another Chinese Megacities**, such as Beijing
  - **Compare to a foreign urban and metropolis context** in the world, such as Paris or Strasbourg
- **Engage new researches in related fields**
- At the basis of a **more comprehensive practice and approach for architects and urban planner** of tomorrow

# contributions and future



- **End of study project at ENSAS**
  - **A Spring for Souls, Rebirth of Shanghainese mourning spaces**
  - Defended in Septembre 2019
  - To solve stakes mentionned in this master thesis, related to **the despatialization and the desocialization of death**
- **PhD thesis subject**
  - **The globalization of cultures**
  - **Convergences and standardization of funeral practices and spaces between France and China**
- Personal construction and introspection work



Strasbourg,  
école d'architecture



同濟大學  
TONGJI UNIVERSITY

# The place of Death in Chinese megacities

*Spatial reflections of Shanghai cemeteries under  
urban transformations*

Master thesis supervisor :  
GAN Jing - 干靚 | Andreea Grigorovoschi

Marie FRUIQUIERE